

## ZEPHYR CLEVIS-CONNECTED HOISTS & TROLLEYS

**CAPACITIES**

1/2 to 10 Tons

**LIFT**

8 Feet Standard

**TROLLEY TYPES**

Plain or Geared

**OPTIONS**Spark & Corrosion Resistance  
Clean Room

Clevis-connected hoists and trolleys are ideal for applications where headroom limitations prohibit a standard trolley suspension or when you want to prevent casual removal of a hoist from the trolley. Design also retains rock-and-swivel flexibility of standard trolley suspension.

Any Zephyr hoist may be converted to clevis connected by removing the suspension hook, replacing with it with a clevis. These clevis-connected hoists may then be paired with a Chester Model PT trolley of the same capacity. See pages 26 through 29 for more information.

**KEY FEATURES**

**CHESTER ZEPHYR CLEVIS-CONNECTED HOISTS & TROLLEYS CONTAIN ALL OF THE SAME KEY FEATURES AS THE HOOK-SUSPENDED MODELS.**



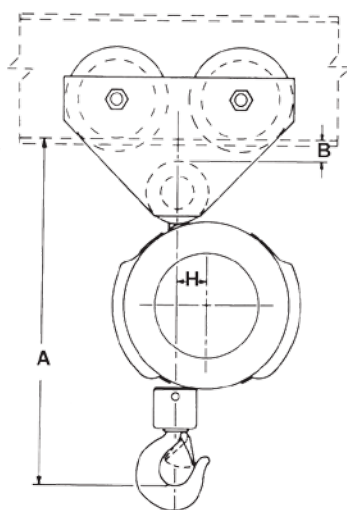

1/2 TO 2 TON

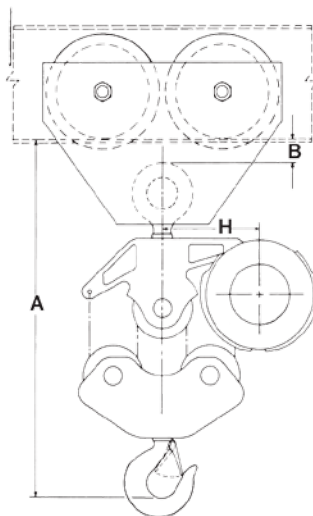

3 TO 10 TON

**SPECIFICATIONS & DIMENSIONS**

Capacity (tons)	Catalog Number	Standard Lift (ft.)	Minimum Headroom with Trolley (in.)	Adjustable For Standard I-Beam Size	Chain Pull to Lift Full Load One Foot (lbs.)	Chain Overhauled to Lift Load One Foot (ft.)	Net Weight with Trolley (lbs.)		Dimensions (in.)		
							Plain	Geared	A	B	C
<b>REGULAR UNITS</b>											
1/2	135 - 1/2	8	13-7/16	4 to 12	31	33	80	-	13-5/8	3/4	1-3/8
1	135 - 1	8	14-3/16	5 to 12	62	33	96	162	14-3/8	1-3/8	1-3/8
1-1/2	135 - 1-1/2	8	18-1/16	6 to 18	57	58	167	196	18-5/16	1-7/16	1-3/4
2	135 - 2	8	18-1/16	6 to 18	76	58	167	196	18-5/16	1-7/16	1-3/4
3	135 - 3	8	26	8 to 18	60	116	284	328	26-1/4	1-1/2	4-7/8
4	135 - 4	8	26-7/8	8 to 24	79	116	323	384	27-1/8	1-3/8	4-7/8
5	135 - 5	8	28-5/16	10 to 24	65	174	480	555	28-5/8	1-7/8	6-3/8
6	135 - 6	8	28-5/16	10 to 24	78	174	480	605	28-5/8	1-7/8	6-3/8
8	135 - 8	8	30-1/8	10 to 24	81	232	560	646	30-7/16	1-15/16	8-1/2
10	135 - 10	8	34	10 to 24	84	290	785	860	34-13/16	2-9/32	10-1/4
<b>SPARK-RESISTANT UNITS</b>											
1/2	13-7/8	8	13-7/8	4 to 12	31	33	80	-	13-5/8	3/4	1-3/8
1	14-5/8	8	14-5/8	5 to 12	62	33	96	162	14-3/8	1-3/8	1-3/8
1-1/2	18-9/16	8	18-9/16	6 to 18	57	58	167	196	18-5/16	1-7/16	1-3/4
2	18-9/16	8	18-9/16	6 to 18	76	58	167	196	18-5/16	1-7/16	1-3/4
3	-	8	-	8 to 18	60	116	284	328	26-1/4	1-1/2	4-7/8
4	27-3/4	8	27-3/4	8 to 24	79	116	323	384	27-1/8	1-3/8	4-7/8
5	28-11/16	8	28-11/16	10 to 24	65	174	480	555	28-5/8	1-7/8	6-3/8
6	29-11/16	8	29-11/16	10 to 24	78	174	480	605	28-5/8	1-7/8	6-3/8
8	32-21/32	8	32-21/32	10 to 24	81	232	560	646	30-7/16	1-15/16	8-1/2
10	35-3/4	8	35-3/4	10 to 24	84	290	785	860	34-13/16	2-9/32	10-1/4