

HAND-PROPELLED, OVERHEAD I-BEAM PT TROLLEYS

CAPACITIES

1/4 to 50 Tons

**BEAM ADJUSTMENT
RANGE**

2.66 to 8 in.

**MINIMUM
RADIUS CURVE**

20 to 120 in.

OPTIONSSpark & Corrosion Resistance
Clean Room

For easy hoist attachment and ease of movement, Chester offers a wide variety of manually operated plain and geared trolleys. These trolleys feature concentrically machined wheels for easy rolling motion as well as high-quality, anti-friction bearings to assure minimal effort is needed for positioning. All capacities feature heavy rolled steel side plates complete with bumper/drop stops as standard to provide a full face bumper to contact beam end stops.

KEY FEATURES**MINIMUM MANUAL EFFORT & EASY MAINTENANCE**

Lifetime-lubricated precision ball bearings in ¼- to 3-ton capacities reduce manual effort and allow for easy maintenance. In 4- to 25-ton capacities, each trolley is equipped with eight sealed and tapered roller bearings that absorb the radial and thrust loads exerted in these heavier sizes while also allowing for ease of use and maintenance.

STABLE AND RIGID CONSTRUCTION

Heavy rolled-steel side plates are shaped to provide stability and rigidity.

LOAD EQUALIZATION & SMOOTH OPERATION

Steel equalizing pins connect the two halves of each trolley, providing load equalization and smooth operation.

DURABLE, SMOOTH-RUNNING TROLLEY WHEELS

Trolley wheels are long-wearing alloy cast iron. Wheel treads are machined to provide smoothest possible rolling motion. Steel axles are rigidly supported in the side frame. Steel trolley blocks reinforce the side plates as well as the equalizing pin.

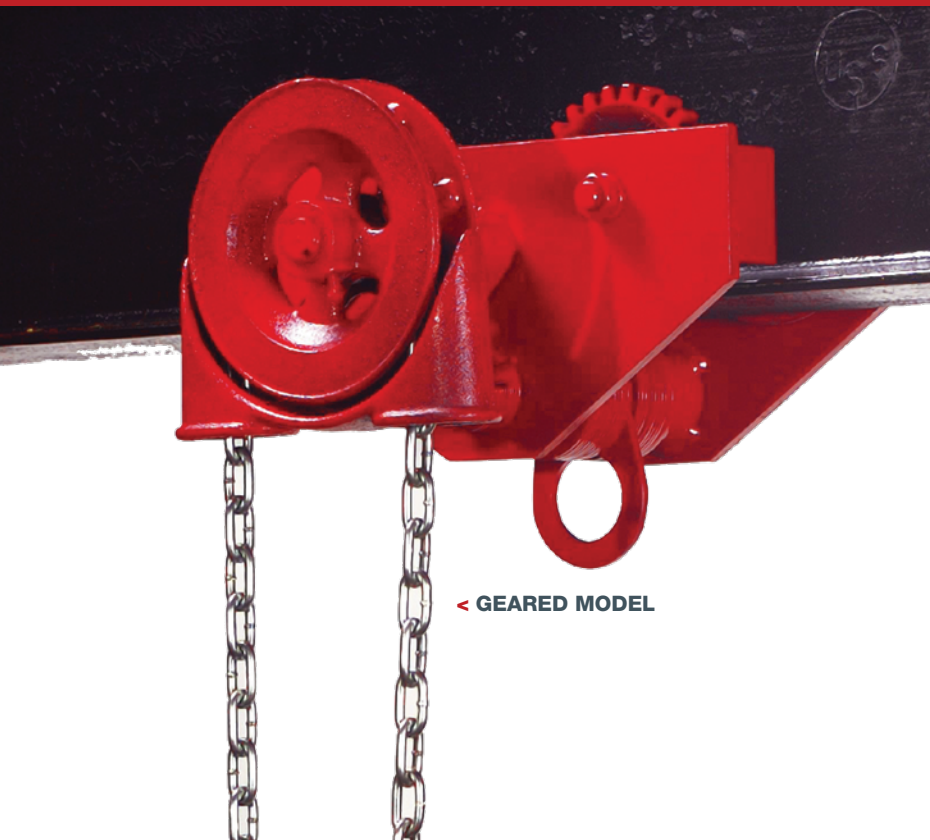

◀ GEARED MODEL

SPARK-RESISTANT OPTIONS

SOLID BRONZE WHEELS

Concentrically machined for smooth rolling motion.

STAINLESS STEEL DROP STOPS

ALUMINUM HAND CHAIN GUARD

**ALUMINUM OR STAINLESS STEEL
HAND CHAIN**

CORROSION-RESISTANT OPTIONS

SPECIAL CORROSION-RESISTANT FINISHES

Created specifically for operation in salt-laden or other corrosive environments.

CLEAN ROOM OPTIONS

FOOD-GRADE EPOXY PAINT

STAINLESS STEEL WHEELS

STAINLESS STEEL BEARINGS

STAINLESS STEEL HAND CHAIN

**COMPLETE STAINLESS STEEL UNITS
AVAILABLE FOR SOME CAPACITIES**

“THE ULTIMATE CLEAN ROOM TROLLEY”



◀ PLAIN MODEL

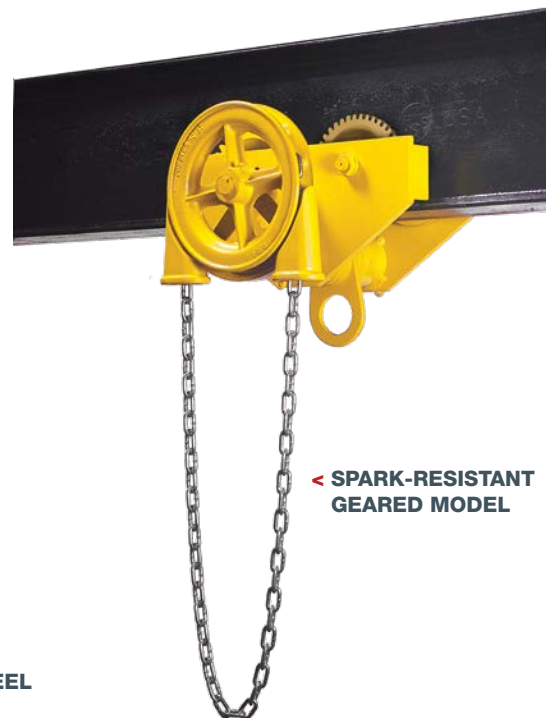

◀ SPARK-RESISTANT
GEARED MODEL

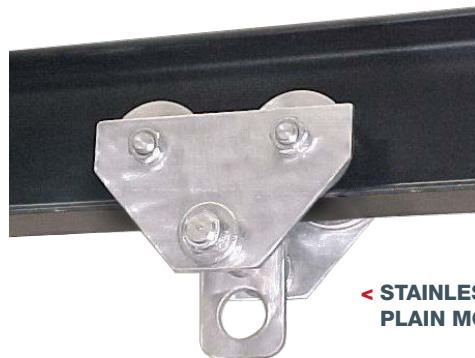

◀ STAINLESS-STEEL
PLAIN MODEL

HAND-PROPELLED, OVERHEAD I-BEAM PT TROLLEYS

SPECIFICATIONS

Capacity (tons)	Catalog Number				Beam Adjustment Range (in.) *	Min. Beam Height (in.) **	Hand Chain Reach from Beam (Geared Trolleys) (ft.)	Minimum Radius Curve (in.) ***	Pounds of Push to Move Plain Trolley, Fully Loaded (lbs.)	Net Weight (lbs.)	
	Plain Trolley	Geared Trolley	Spark-Resistant Plain Trolley	Spark-Resistant Geared Trolley						Plain Trolley	Geared Trolley
1/4	1641-0025	–	1641-0025SR	–	2.66 to 5.0	4	8	20	7	23	38
1/2	1641-0050	–	1641-0050SR	–	2.66 to 5.0	4	8	20	14	23	38
1	1641-0100	1642-0100	1641-0100SR	1642-0100SR	3 to 6	5	8	24	18	43	62
1-1/2	1641-0150	1642-0150	1641-0150SR	1642-0150SR	3 to 6	5	8	24	28	45	65
2	1641-0200	1642-0200	1641-0200SR	1642-0200SR	3.33 to 6.25	6	8	30	38	67	90
3	1641-0300	1642-0300	1641-0300SR	1642-0300SR	3.33 to 6.25	6	8	30	44	70	93
4	1641-0400	1642-0400	1641-0400SR	1642-0400SR	4 to 7	8	8	36	59	155	184
5	1641-0500	1642-0500	1641-0500SR	1642-0500SR	4 to 7	8	8	36	61	160	188
6	1641-0600	1642-0600	1641-0600SR	1642-0600SR	4 to 7	8	8	36	73	160	188
8	1641-0800	1642-0800	1641-0800SR	1642-0800SR	4.62 to 8	10	8	60	85	300	347
10	1641-1000	1642-1000	1641-1000SR	1642-1000SR	4.62 to 8	10	8	60	90	310	360
12	1641-1200	1642-1200	1641-1200SR	1642-1200SR	4.62 to 8	10	8	60	110	310	360
16	1641-1600	1642-1600	1641-1600SR	1642-1600SR	6 to 8	12	8	96	120	600	650
20	1641-2000	1642-2000	1641-2000SR	1642-2000SR	6 to 8	12	8	96	156	610	660
25	1631-2500	1632-2500	1631-2500SR	1632-2500SR	6 to 8	18	8	120	195	1045	1200
30	1641-3000	1642-3000	1641-3000SR	1642-3000SR	7 to 8	24	8	–	240	1520	1615
40	1641-4000	1642-4000	1641-4000SR	1642-4000SR	7 to 8	24	8	–	312	1776	1886
50	1631-5000	1632-5000	1631-5000SR	1632-5000SR	7 to 8	24	8	–	390	2676	2831

* NOTE: Consult factory for beams outside of this standard range.

** NOTE: Beam height shown is for proper wheel running clearance only. The customer must verify their chosen beam is adequate for the intended application and loads. Consult factory for beams smaller than the minimum specified.

***NOTE: Minimum radius applies to minimum flange width and may vary with beam. For curve applications consult factory. Curves must be specified when ordering.

1/4 through 20 ton units are supplied straight sided with universal wheels for operation on flat or tapered beams.

For patented track applications consult factory.

25 and 50 ton units are supplied with canted side plates for operation on standard American tapered I-beams.

For other beams consult factory.

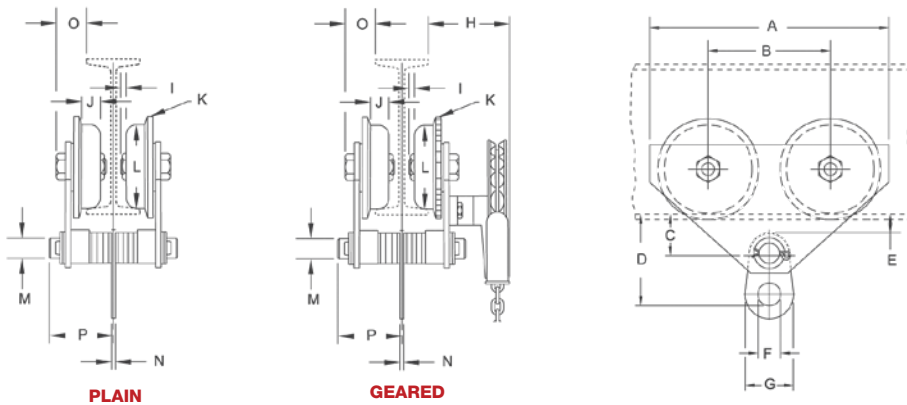

DIMENSIONS

Capacity (tons)	Dimensions (In.)															
	A	B	C	D	E	F	G	H	I	J	K	L	M	N	O	P
PLAIN & GEARED TROLLEY																
1/4	11-1/2	6	1-7/8	4-7/8	7/8	1-3/4	2-3/4	6	0	7/8	4	2-7/8	1	1/4	2	4-1/8
1/2	13-1/4	6-3/4	2-1/4	5-3/8	1	1-3/4	3	6-1/8	0	1-1/8	5	3-3/4	1-1/4	1/4	1-3/4	4-3/4
1	13-1/4	6-3/4	2-1/4	5-5/8	1	2	3-1/4	6-1/8	0	1-1/8	5	3-3/4	1-1/4	3/8	1-3/4	4-3/4
1-1/2	13-1/4	6-3/4	2-1/4	5-5/8	1	2	3-1/4	6-1/8	0	1-1/8	5	3-3/4	1-1/4	3/8	1-3/4	4-3/4
2	15-5/8	7-5/8	2-5/8	6-3/4	1-1/8	2-1/8	3-5/8	6-1/8	0	1-1/8	6	4-1/2	1-1/2	3/8	2-1/8	5-1/4
3	15-5/8	7-5/8	2-5/8	6-7/8	1-1/8	2-1/4	4	6-1/8	0	1-1/8	6	4-1/2	1-1/2	1/2	2-1/8	5-1/4
4	18-3/4	8-1/2	3-1/4	8-3/8	1-1/4	2-3/4	4-3/4	8-1/8	1/8	1-3/8	8	6-3/8	2	5/8	2-5/8	6-1/8
5	18-3/4	8-1/2	3-1/4	8-5/8	1-1/4	3	5-1/2	8-1/8	1/8	1-3/8	8	6-3/8	2	5/8	2-5/8	6-1/8
6	18-3/4	8-1/2	3-1/4	8-5/8	1-1/4	3	5-1/2	8-1/8	1/8	1-3/8	8	6-3/8	2	5/8	2-5/8	6-1/8
8	23-5/8	10-5/8	3-7/8	10-5/8	1-3/8	3-1/2	6-1/2	9	1/8	1-11/16	10	8-1/4	2-1/2	3/4	3-1/4	6-7/8
10	23-5/8	10-5/8	3-7/8	11-1/8	1-3/8	4-1/2	8	9	1/8	1-11/16	10	8-1/4	2-1/2	1	3-1/4	6-7/8
12	23-5/8	10-5/8	3-7/8	11-1/8	1-3/8	4-1/2	8	9	1/8	1-11/16	10	8-1/4	2-1/2	1	3-1/4	6-7/8
16	28	12	4-3/4	13-3/4	1-7/16	4	9	10-11/16	1/4	1-3/4	11-11/16	9-3/4	3-1/4	1-1/4	4-5/8	7-5/8
20	28	12	4-3/4	16-3/4	1-7/16	4-1/2	10	10-11/16	1/4	1-3/4	11-11/16	9-3/4	3-1/4	1-1/4	4-5/8	7-5/8
25	28-1/4	14	5-7/8	16-3/4	2-1/8	4	10	14-1/2	5/16	2	13-1/2	11-3/4	3-1/4	1-3/4	7	8-1/4
30	Consult Factory															
40	Consult Factory															
50	Consult Factory															
PLAIN & GEARED TROLLEY, SPARK-RESISTANT																
1/4	11-1/2	6	1-7/8	4-7/8	7/8	1-3/4	2-3/4	6	0	7/8	4	2-7/8	1	1/4	2	4-1/8
1/2	13-1/4	6-3/4	2-1/4	5-3/8	1	1-3/4	3	6-1/8	0	1-1/8	5	3-3/4	1-1/4	1/4	1-3/4	4-3/4
1	13-1/4	6-3/4	2-1/4	5-5/8	1	2	3-1/4	6-1/8	0	1-1/8	5	3-3/4	1-1/4	3/8	1-3/4	4-3/4
1-1/2	13-1/4	6-3/4	2-1/4	5-5/8	1	2	3-1/4	6-1/8	0	1-1/8	5	3-3/4	1-1/4	3/8	1-3/4	4-3/4
2	15-5/8	7-5/8	2-5/8	6-3/4	1-1/8	2-1/8	3-5/8	6-1/8	0	1-1/8	6	4-1/2	1-1/2	3/8	2-1/8	5-1/4
3	15-5/8	7-5/8	2-5/8	6-7/8	1-1/8	2-1/4	4	6-1/8	0	1-1/8	6	4-1/2	1-1/2	1/2	2-1/8	5-1/4
4	18-3/4	8-1/2	3-1/4	8-3/8	1-1/4	2-3/4	4-3/4	8-1/8	1/8	1-3/8	8	6-3/8	2	5/8	2-5/8	6-1/8
5	18-3/4	8-1/2	3-1/4	8-5/8	1-1/4	3	5-1/2	8-1/8	1/8	1-3/8	8	6-3/8	2	5/8	2-5/8	6-1/8
6	18-3/4	8-1/2	3-1/4	8-5/8	1-1/4	3	5-1/2	8-1/8	1/8	1-3/8	8	6-3/8	2	5/8	2-5/8	6-1/8
8	23-5/8	10-5/8	3-7/8	10-5/8	1-3/8	3-1/2	6-1/2	9	1/8	1-11/16	10	8-1/4	2-1/2	3/4	3-1/4	6-7/8
10	23-5/8	10-5/8	3-7/8	11-1/8	1-3/8	4-1/2	8	9	1/8	1-11/16	10	8-1/4	2-1/2	1	3-1/4	6-7/8
12	23-5/8	10-5/8	3-7/8	11-1/8	1-3/8	4-1/2	8	9	1/8	1-11/16	10	8-1/4	2-1/2	1	3-1/4	6-7/8
16	28	12	4-3/4	13-3/4	1-7/16	4	9	10-11/16	1/4	1-3/4	11-11/16	9-3/4	3-1/4	1-1/4	4-5/8	7-5/8
20	28	12	4-3/4	16-3/4	1-7/16	4-1/2	10	10-11/16	1/4	1-3/4	11-11/16	9-3/4	3-1/4	1-1/4	4-5/8	7-5/8
25	28-1/4	14	5-7/8	16-3/4	2-1/8	4	10	14-1/2	5/16	2	13-1/2	11-3/4	3-1/4	1-3/4	7	8-1/4
30	Consult Factory															
40	Consult Factory															
50	Consult Factory															

NOTE: To better illustrate wheels, bumpers have been omitted from the drawings on this page. Wheels with convex treads are standard on all capacities 1/4 ton through 20 ton. 30, 40 & 50 ton trolleys are available furnished in tandem construction. Consult factory for dimensions. Dimensions vary proportionately with beam size.

HAND-PROPELLED, OVERHEAD ADJUSTABLE **SWIVEL-TRUCK TROLLEYS**

CAPACITIES

1/4 to 6 Tons

**BEAM ADJUSTMENT
RANGE**

2-5/8 to 8 in.

**MINIMUM
RADIUS CURVE**

9-7/8 to 33-7/8 in.

OPTIONSSpark & Corrosion Resistance
Wide Flange or Patented Track
Clean Room

Chester swivel-truck trolleys are the ideal choice when your application requires a trolley that can traverse the tightest curves with ease while maintaining an absolute minimum distance between the runway beam and load eye. The forged steel load eye on these swivel-truck trolleys is suspended on a special load bar carried at each end by a swiveling two-wheeled trolley unit. Design allows for easy attachment of hook-suspended Chester Zephyr hoists.

KEY FEATURES**MINIMUM MANUAL EFFORT & EASY MAINTENANCE**

Lifetime-lubricated precision ball bearings in 1/4- to 2-ton capacities reduce manual effort and allow for easy maintenance. 3- to 6-ton capacity trolleys are equipped with eight sealed and tapered roller bearings that also reduce effort and promote easy maintenance.

DURABLE, SMOOTH-RUNNING TROLLEY WHEELS

Trolley wheels are cast iron and through hardened for long life. Wheel treads are concentrically machined to provide smoothest possible rolling motion.

Trolleys may be special ordered for operation on wide flange beams or patented track. A trolley track lock, trolley bumpers and anti-drop lugs can also be ordered with these units.

OPTIONS & CONFIGURATIONS

SWIVEL-TRUCK TROLLEYS ◀



◀ **GEARED MODEL**
with optional anti-drop lugs

SPARK-RESISTANT OPTIONS

SOLID BRONZE WHEELS

Concentrically machined for smooth rolling motion.

STAINLESS STEEL DROP STOPS

ALUMINUM HAND CHAIN GUARD

ALUMINUM OR STAINLESS STEEL

HAND CHAIN

CORROSION-RESISTANT OPTIONS

SPECIAL CORROSION-RESISTANT FINISHES

Created specifically for operation in salt-laden or other corrosive environments.

CLEAN ROOM OPTIONS

FOOD-GRADE EPOXY PAINT

STAINLESS STEEL WHEELS

STAINLESS STEEL BEARINGS

STAINLESS STEEL HAND CHAIN



◀ **SPARK-RESISTANT GEARED MODEL**
with optional anti-drop lugs

HAND-PROPELLED, OVERHEAD ADJUSTABLE SWIVEL-TRUCK TROLLEYS

SPECIFICATIONS

Capacity (tons)	Catalog Number		Beam Adjustment Range (in.) *	Minimum Beam Height (in.) **	Hand Chain Reach from Beam (Geared Trolleys) (ft.)	Minimum Radius Curve (in.) ***	Pounds of Push to Move Plain Trolley, Fully Loaded (lbs.)	Net Weight (lbs.)	
	Plain Trolley	Geared Trolley						Plain Trolley	Geared Trolley
1/4	1831-1/4	1832-1/4	2-5/8 to 4-5/8	4	8	9-7/8	7	45	63
1/2	1831-1/2	1832-1/2	2-5/8 to 4-5/8	4	8	9-7/8	14	45	63
1	1831-1	1832-1	3 to 4-5/8	5	8	9-7/8	18	58	75
1-1/2	1831-1-1/2	1832-1-1/2	3-5/8 to 5-1/2	6	8	19-1/2	28	83	105
2	1831-2	1832-2	3-5/8 to 5-1/2	6	8	19-1/2	38	83	105
3	1831-3	1832-3	4 to 7	8	8	15-3/8	44	155	185
4	1831-4	1832-4	4 to 7	8	8	15-3/8	59	155	185
5	1831-5	1832-5	4-5/8 to 8	10	8	33-7/8	61	274	303
6	1831-6	1832-6	4-5/8 to 8	10	8	33-7/8	73	274	303

* NOTE: Consult factory for beams outside of this standard range.
 ** NOTE: Beam height shown is for proper wheel running clearance only. The customer must verify their chosen beam is adequate for the intended application and loads. Consult factory for beams smaller than the minimum specified.
 ***NOTE: Minimum radius applies to minimum flange width and may vary with beam. For curve applications consult factory. Curves must be specified when ordering. Convex tread wheels are standard for standard I-beams for all capacities. Trolleys operating on patented track or wide flange beams will have flat tread wheels. Patented track and wide flange beam applications must be specified. For patented track applications consult factory. For other beams consult factory.

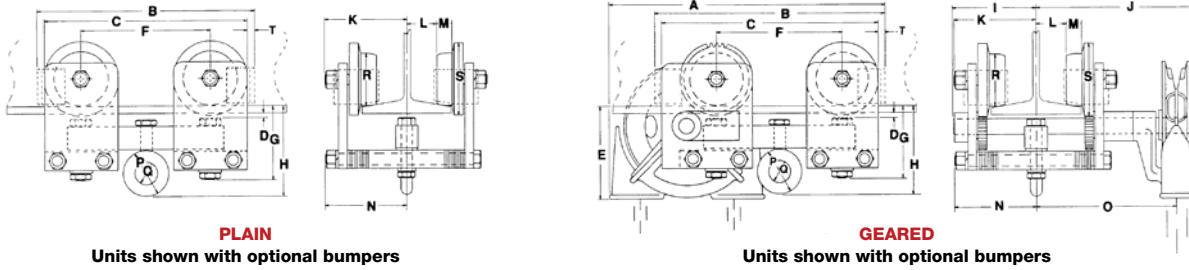

PLAIN
Units shown with optional bumpers

GEARED
Units shown with optional bumpers

DIMENSIONS

Capacity (tons)	Dimensions (In.)																			
	A	B	C	D**	E	F	G	H	I	J	K*	L*	M	N	O	P	Q	R	S	T
PLAIN TROLLEY																				
1/4	-	11-3/4	11	5/16	-	7	4-1/16	4-7/8	-	-	4-1/2	1-9/16	7/8	4-5/16	-	2-1/2	1-1/4	2-7/8	3-5/8	3/8
1/2	-	11-3/4	11	5/16	-	7	4-1/16	4-7/8	-	-	4-1/2	1-9/16	7/8	4-5/16	-	2-1/2	1-1/4	2-7/8	3-5/8	3/8
1	-	13	12	5/16	-	7	4-3/8	5-1/8	-	-	4-3/4	1-1/4	1-3/32	4-3/8	-	2-1/2	1-1/4	3-3/4	5	1
1-1/2	-	16-1/4	14-1/4	1/4	-	8-1/4	4-1/2	5-1/2	-	-	5	1-3/4	1-1/8	5	-	3	1-1/2	4-1/2	6	1
2	-	16-1/4	14-1/4	1/4	-	8-1/4	4-1/2	5-1/2	-	-	5	1-3/4	1-1/8	5	-	3	1-1/2	4-1/2	6	1
3	-	18-3/4	17-1/2	1/4	-	9-1/2	6-1/2	8-1/32	-	-	6	2-1/16	1-11/32	6	-	3-3/4	2	6-3/8	8	1-1/8
4	-	18-3/4	17-1/2	1/4	-	9-1/2	6-1/2	8-1/32	-	-	6	2-1/16	1-11/32	6	-	3-3/4	2	6-3/8	8	1-1/8
5	-	22-3/4	20-3/4	3/16	-	11-3/4	7-5/8	10-3/8	-	-	7-5/8	2-11/16	1-7/16	7-1/2	-	5-1/2	3	7-3/16	9	2-1/4
6	-	22-3/4	20-3/4	3/16	-	11-3/4	7-5/8	10-3/8	-	-	7-5/8	2-11/16	1-7/16	7-1/2	-	5-1/2	3	7-3/16	9	2-1/4
GEARED TROLLEY																				
1/4	15-3/8	12-3/4	12	1/4	5-1/8	7	4-1/16	4-7/8	4-7/19	9-1/8	4-1/2	1-9/16	7/8	4-5/16	7-7/8	2-1/2	1-1/4	2-7/8	4	3/8
1/2	15-3/8	12-3/4	12	1/4	5-1/8	7	4-1/16	4-7/8	4-7/19	9-1/8	4-1/2	1-9/16	7/8	4-5/16	7-7/8	2-1/2	1-1/4	2-7/8	4	3/8
1	15-13/16	13-1/2	12-7/8	5/16	5-5/16	7	4-3/8	5-1/8	4-7/16	9-1/8	4-3/4	1-1/4	1-3/32	4-3/8	7-7/8	2-1/2	1-1/4	3-3/4	5	1
1-1/2	17-3/4	16-1/4	14-1/4	1/4	5-7/16	8-1/4	4-1/2	5-1/2	4-13/16	8-3/4	5	1-3/4	1-1/8	5	7-7/8	3	1-1/2	4-1/2	6	1
2	17-3/4	16-1/4	14-1/4	1/4	5-7/16	8-1/4	4-1/2	5-1/2	4-13/16	8-3/4	5	1-3/4	1-1/8	5	7-7/8	3	1-1/2	4-1/2	6	1
3	20-1/4	18-3/4	17-1/2	1/4	6-5/8	9-1/2	6-1/2	8-1/32	5-7/8	9-3/4	6	2-1/16	1-11/32	6	8-1/2	3-3/4	2	6-3/8	8	1-1/8
4	20-1/4	18-3/4	17-1/2	1/4	6-5/8	9-1/2	6-1/2	8-1/32	5-7/8	9-3/4	6	2-1/16	1-11/32	6	8-1/2	3-3/4	2	6-3/8	8	1-1/8
5	25-9/16	22-1/4	20-3/4	1/4	8-7/16	11-3/4	7-5/8	10-3/8	6-13/16	11-5/16	7-5/8	2-11/16	1-7/16	7-1/2	10	5-1/2	3	7-3/16	9	2-1/4
6	25-9/16	22-1/4	20-3/4	1/4	8-7/16	11-3/4	7-5/8	10-3/8	6-13/16	11-5/16	7-5/8	2-11/16	1-7/16	7-1/2	10	5-1/2	3	7-3/16	9	2-1/4
PLAIN TROLLEY, SPARK-RESISTANT																				
1/4	-	11-3/4	11	5/16	-	7	4-1/16	4-7/8	-	-	4-1/2	1-9/16	7/8	4-5/16	-	2-1/2	1-1/4	2-7/8	3-5/8	3/8
1/2	-	11-3/4	11	5/16	-	7	4-1/16	4-7/8	-	-	4-1/2	1-9/16	7/8	4-5/16	-	2-1/2	1-1/4	2-7/8	3-5/8	3/8
1	-	13	12	5/16	-	7	4-3/8	5-1/8	-	-	4-3/4	1-1/4	1-3/32	4-3/8	-	2-1/2	1-1/4	3-3/4	5	1
1-1/2	-	16-1/4	14-1/4	1/4	-	8-1/4	4-1/2	5-1/2	-	-	5	1-3/4	1-1/8	5	-	3	1-1/2	4-1/2	6	1
2	-	16-1/4	14-1/4	1/4	-	8-1/4	4-1/2	5-1/2	-	-	5	1-3/4	1-1/8	5	-	3	1-1/2	4-1/2	6	1
3	-	18-3/4	17-1/2	1/4	-	9-1/2	6-1/2	8-1/32	-	-	6	2-1/16	1-11/32	6	-	3-3/4	2	6-3/8	8	1-1/8
4	-	18-3/4	17-1/2	1/4	-	9-1/2	6-1/2	8-1/32	-	-	6	2-1/16	1-11/32	6	-	3-3/4	2	6-3/8	8	1-1/8
5	-	22-3/4	20-3/4	3/16	-	11-3/4	7-5/8	10-3/8	-	-	7-5/8	2-11/16	1-7/16	7-1/2	-	5-1/2	3	7-3/16	9	2-1/4
6	-	22-3/4	20-3/4	3/16	-	11-3/4	7-5/8	10-3/8	-	-	7-5/8	2-11/16	1-7/16	7-1/2	-	5-1/2	3	7-3/16	9	2-1/4
GEARED TROLLEY, SPARK-RESISTANT																				
1/4	15-3/8	12-3/4	12	1/4	5-1/8	7	4-1/16	4-7/8	4-7/19	9-1/8	4-1/2	1-9/16	7/8	4-5/16	7-7/8	2-1/2	1-1/4	2-7/8	4	3/8
1/2	15-3/8	12-3/4	12	1/4	5-1/8	7	4-1/16	4-7/8	4-7/19	9-1/8	4-1/2	1-9/16	7/8	4-5/16	7-7/8	2-1/2	1-1/4	2-7/8	4	3/8
1	15-13/16	13-1/2	12-7/8	5/16	5-5/16	7	4-3/8	5-1/8	4-7/16	9-1/8	4-3/4	1-1/4	1-3/32	4-3/8	7-7/8	2-1/2	1-1/4	3-3/4	5	1
1-1/2	17-3/4	16-1/4	14-1/4	1/4	5-7/16	8-1/4	4-1/2	5-1/2	4-13/16	8-3/4	5	1-3/4	1-1/8	5	7-7/8	3	1-1/2	4-1/2	6	1
2	17-3/4	16-1/4	14-1/4	1/4	5-7/16	8-1/4	4-1/2	5-1/2	4-13/16	8-3/4	5	1-3/4	1-1/8	5	7-7/8	3	1-1/2	4-1/2	6	1
3	20-1/4	18-3/4	17-1/2	1/4	6-5/8	9-1/2	6-1/2	8-1/32	5-7/8	9-3/4	6	2-1/16	1-11/32	6	8-1/2	3-3/4	2	6-3/8	8	1-1/8
4	20-1/4	18-3/4	17-1/2	1/4	6-5/8	9-1/2	6-1/2	8-1/32	5-7/8	9-3/4	6	2-1/16	1-11/32	6	8-1/2	3-3/4	2	6-3/8	8	1-1/8
5	25-9/16	22-1/4	20-3/4	1/4	8-7/16	11-3/4	7-5/8	10-3/8	6-13/16	11-5/16	7-5/8	2-11/16	1-7/16	7-1/2	10	5-1/2	3	7-3/16	9	2-1/4
6	25-9/16	22-1/4	20-3/4	1/4	8-7/16	11-3/4	7-5/8	10-3/8	6-13/16	11-5/16	7-5/8	2-11/16	1-7/16	7-1/2	10	5-1/2	3	7-3/16	9	2-1/4

NOTE: Dimensions based on standard beams at maximum flange width.
 * Dimension will vary with beam size
 ** Minimum under-the-beam clearance not necessarily at point indicated. Dimension will also vary with beam size

ZEPHYR ACCESSORIES

Standard and custom accessories are available for most Chester Zephyr hoist and trolley models. When accessories other than those shown in this catalog are required, contact your Columbus McKinnon sales representative.

TROLLEY TRACK LOCKS

Quick-acting trolley track locks can be supplied with any Chester Model PT trolley or Zephyr trolley hoist. Locks are available as trailer type or built into the trolley. Lever operation, or chain actuated as shown, is optional. Chester track lock jaws are made of steel and grooved to bite and hold firmly to the flange of the runway beam. Jaws will hold with a fully loaded trolley (up to 1,500 lb. in-line pull). Lock is designed to prevent additional load pressures from being applied to the trolley wheels when lock is actuated. Track clamps are available with optional stainless steel jaws and hand chain for spark-resistant applications.



OVERLOAD LIMITERS

Overload limiters are available as an option on all Chester Zephyr hand chain hoists. This “slip clutch” device will allow the hoist to lift its rated load, but is designed to prohibit lifting an overload that could cause damage to the hoist. Overload limiters do not increase the envelope dimensions of the hoist.

CHAIN CONTAINERS

Chain containers are designed to receive idle load chain as it reeves over the load sheave when lifting a load. This prevents the idle chain from interfering or marring and scratching the load or surrounding surfaces. Compact design helps maintain best possible headroom. Containers are available for most Chester hoist models.



BULK HAND CHAIN

Bulk hand chain is available in zinc-plated steel, aluminum and stainless steel to suit nearly any application. This chain can be purchased by the lineal foot and is also available in barrel lengths, providing considerable cost savings versus standard per-foot pricing.

SWINGING HAND WHEEL GUARDS

Used in conjunction with a hand wheel, swinging hand wheel guards help keep the chain seated in the pocketed hand wheel, but also pivots freely on the hand wheel shaft to allow the hand chain to move freely. Guards are available in cast iron or aluminum. Cast iron guards can be supplied with copper plating or electro-less nickel plating for special applications.

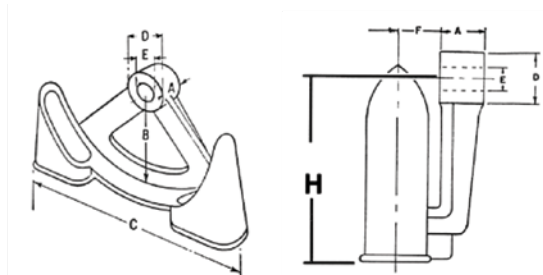

DIMENSIONS

Catalog Number	Dimensions (in.)							Net Weight (lbs.)
	A	B	C	D	E Standard Bore*	F	H	
REGULAR UNITS								
C-37175 (7 PG)	1	2-3/4	5-11/16	1-1/2	7/8	11/16	3-3/8	1-1/2
C-9121-0075 (8 PG)	1-1/4	3-3/4	8-3/4	2	7/8	1-1/8	4-1/16	3-1/2
C-9121-0100 (12 PG)	1-3/8	4-7/8	11-1/8	1- 13/16	7/8 & 1-1/4	13/16	5-3/8	5
C-9121-0150 (15 PG)	1-3/4	4-15/16	13-1/2	2-1/4	7/8 & 1-1/4	1	6-7/8	7
C-9121-1000 (20 PG)	1-3/4	7-3/8	17-1/16	2-1/4	1-1/4	1	8-1/8	11
C-9121-2500 (25 PG)	1-3/4	9	21-3/8	2-3/4	1-1/4 & 1-3/8	1	9-15/16	13

* Special dimensions can be furnished.

POCKETED HAND WHEELS

Pocketed hand wheels are designed for use with the same hand chains used on our Zephyr hand hoists. Hand chain wheels are made of durable ductile cast iron and are available in a variety of finishes, including zinc plating, nickel plating and oil-based enamel or epoxy paint.

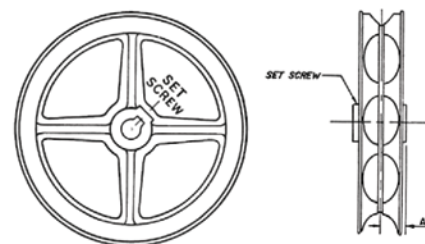

DIMENSIONS

Catalog Number	Dimensions (in.)									Net Weight (lbs.)
	Chain Size	Pitch Diameter	Outside Diameter	Regular Bore *	Max. Bore *	Regular Keyway	Length through Hub	Hub Diameter	A**	
REGULAR UNITS										
C-36072 (7 P)	5MM	4-1/16	5	7/8	1	1/4 x 1/8	1-7/32	1-3/4	39/64	3-1/4
C-9120-0075 (8 P)	1/4	5-1/4	7	7/8	1-1/4	1/4 x 1/8	1-7/8	1-11/16	1	4-1/2
C-9120-0100 (12 P)	1/4	8-1/4	9-5/16	7/8 & 1-1/4	1-1/4	1/4 x 1/8	1-29/32	1-3/4	3/4	9
C-9120-0150 (15 P)	1/4	10	11-5/16	7/8 & 1-1/4	1-3/4	1/4 x 1/8	1-7/8	2-3/8	15/16	12
C-9120-1000 (20 P)	1/4	13-3/8	14-3/8	1-1/4	1-3/4	5/16 x 5/32	1-7/8	2-3/8	15/16	22
C-9120-2500 (25 P)	1/4	16-5/8	17-3/4	1-1/4 & 1-3/8	2	5/16 x 5/32	2-3/4	2-3/4	15/16	32

* Non-Standard bore available. Contact Factory.

** Center-line of hand chain to back.