

PROSTAR™

ELECTRIC CHAIN HOIST

Lightweight and quiet, the CM Prostar is designed and built for the unique rigging needs encountered at small venues. This portable hoist features standard overload protection to help ensure structural and operator safety. New swivel hook suspension allows for easy attachment to slings and pick points.

CAPACITIES
300 to 1000 lbs.

LIFT
60 feet standard

SPEEDS
6 to 40 feet/minute

VOLTAGES
1-phase & 3-phase available



KEY FEATURES

DC ELECTRO-MECHANICAL BRAKE

Non-adjusting for low maintenance and quiet operation.

GEARING

Precision-machined gears are heat treated for strength and durability.

CHAIN GUIDE

One piece chain guide won't jam and allows for smooth operation.

HOUSING

Lightweight and durable cast aluminum with black, powder coat finish for low visibility.

LIFT WHEEL

CM patented 10-pocket, oblique-lay lift wheel for quiet and smooth operation.

LOW VOLTAGE CONTROL

110 Volt for long cable runs without voltage drop. 24 and 48 Volt optional.

DUTY CYCLE

H-4 duty rated, designed for heavy-duty applications.

STANDARD FEATURES

OVERLOAD PROTECTION

Helps prevent lifting of dangerous overloads.

CHAIN STOP

Mounted on load chain to prevent over travel.

METRIC RATED

LOAD CHAIN

Designed and manufactured by Stuart Rush. Zinc plated to protect against corrosion. Optional black phosphate finish.

THE INDUSTRY'S BEST LIFETIME WARRANTY

MEETS OR EXCEEDS WORLD STANDARDS

OPTIONAL FEATURES

CHAIN BAG

Easy-to-mount, cloth-type bags.

DOUBLE BRAKE

ENCODER

SWIVEL HOOK SUSPENSION

NOW AVAILABLE WITH OPTIONAL SWIVEL HOOK SUSPENSION

Get the versatility and flexibility you need to rig truss, lighting and audio in confined spaces. Optional swivel hook rotates a full 360° to allow for easy attachment to slings and pick points.



Swivel Hook with Latch

Swivel Hook with Latchlok® Latch



PROSTAR™ ELECTRIC CHAIN HOIST

CLEARANCE DIMENSIONS (IN.)

Reeving	A	B	C
Single	11	2-15/16	2-7/8
Double	12-1/8	3-1/2	2-3/8

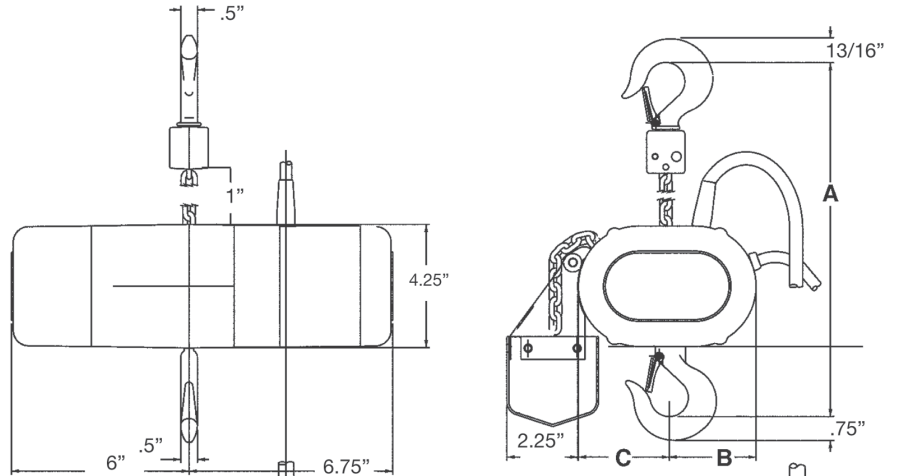

SPECIFICATIONS

Product Code	Capacity (lbs.)	Voltage	Lifting Speed (FPM)	Number of Chains	Standard Lifts* (ft.)	Motor HP	Weight (lbs.)
2049CF	300	115-1-60	16	1	60	1/6	49
2041CF †		220-1-50	16	1	60	1/6	49
2042CF		230-3-50/60	16	1	60	1/6	49
2043CF		380/415-3-50	16	1	60	1/6	49
		440/460-3-60					
2018CF	500	115-1-60	12	1	60	1/6	49
2127CF		230-3-50/60	16	1	60	1/6	49
2128CF		380/415-3-50 440-460-3-60	16	1	60	1/6	49
2050CF	600	115-1-60	8	2	60	1/6	67
2044CF †		220-1-50	8	2	60	1/6	67
2045CF		230-3-50/60	8	2	60	1/6	67
		380/415-3-50 440/460-3-60					
2046CF	1000	230-3-50/60	8	2	60	1/6	67
2129CF		380/415-3-50	8	2	60	1/6	67
2130CF		440/460-3-60					

All models, contactor located in hoist body.
 * Base model, longer or shorter lifts available.
 † Hoists are 220-1-50 single phase only.
 Not available 220-1-60.

SWIVEL HOOKS (OPTIONAL)

Product Code	Description
10001130K	Shopstar/Prostar Swivel Latch-Type Hook Suspension
10001297K	Shopstar/Prostar Swivel Latchlok Hook Suspension

CHAIN CONTAINERS (OPTIONAL)

Product Code	Max. Length of Lift (ft.)		Weight (lbs.)
	1-Chain Single	2-Chain Double	
2063	10	N/A	1
2064	20	10	1.5
2065	40	20	1.5
2066	60	30	1.5
2058	80	40	2.25
2067	120	60	2.25



LIFTING SOLUTIONS



USA & CA
 p: 888.376.7510

WWW.STUART-RUSH.COM