



LODESTAR® NH
ELECTRIC CHAIN HOIST



LODESTAR NH

First introduced in 1955, the CM® Lodestar® was engineered to be the best electric chain hoist in the world. Developed through meticulous engineering and American manufacturing know-how, we weren't interested in building a hoist that merely performed, we wanted to create something extraordinary.

Lodestar – iconic in name and legendary in performance – is recognized as the standard in the overhead lifting industry. Generations of professional riggers have come to rely on the CM Lodestar for the most demanding and challenging applications. For this reason, we've never stopped reinventing and improving it to satisfy the needs of every customer – that's the cornerstone of how we do business and part of our commitment to excellence.

Now, the next-generation Lodestar NH features quiet operation, an environmentally friendly design, easy access to key components, high duty cycles, less maintenance and enhanced safety features. Every Lodestar NH is designed, built and tested to our exacting standards that not only meet, but surpass industry requirements.

Available as individual units, in hoist/trolley combinations, or as integral components of complete lifting systems, the Lodestar NH takes lifting to new heights for professionals in any industry.

With a history of unsurpassed performance and over a million units sold, the next generation of Lodestar continues this legacy.

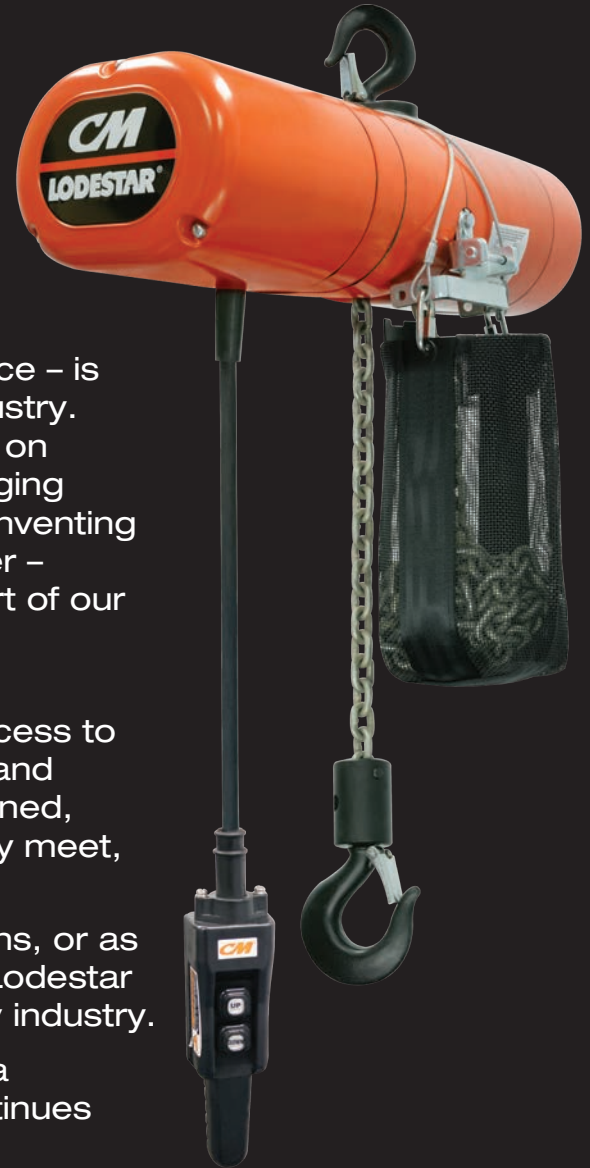

**LIFETIME
WARRANTY™**

Legendary in performance, the CM[®] Lodestar[®] NH electric chain hoist features quiet operation, an environmentally friendly design, easy access to components, high duty cycles, less maintenance and enhanced safety features.

Capacity: 1/8 to 3 tons | LIFT: Up to 20 ft

FEATURES AND BENEFITS

LESS MAINTENANCE & EASIER INSPECTION

- Brake location allows for quick access and easy inspection.
- Lifetime grease-lubricated gearbox means no oil change out is required. Precision gears provide better wear and longer life.
- Clutch located outside the gearbox enables easy access which eliminates the need for complete disassembly and reduces downtime.

IMPROVED SERVICEABILITY

Easy access to the clutch, motor, electrical control panel, and brake assembly.

LONGER SERVICE LIFE

- Heavy-duty DC brake is designed for a long service life.
- Lifetime grease-lubricated gearbox and helical gearing ensures better wear and smooth operation.
- Heavy-duty rated motor.

OPTIONAL FEATURES

DOUBLE DC BRAKE

Two independent-acting DC Brakes for redundant braking. Field Installation Kit available.

AC ELECTRIC BRAKE

SWIVEL HOOK

QUIETER OPERATION

80% reduction in sound pressure as compared to the classic Lodestar.

IMPROVED LOAD SAFETY

Clutch is located outside the load path, preventing slipping of the load in an overload condition when the brake is not powered.

IMPROVED CHAIN LIFE

5-Pocket Lift Wheel provides better chain and lift wheel engagement for smoother lifting and reduced vibration, equating to less wear and a longer chain life. Zinc plating protects chain from environmental conditions.

EASY ACCESS CONTROL PANEL

Finger-safe wiring and plug-and-play connectors on the control panel allow for quick voltage change, easy access to terminal strips and simple fuse installation.

ZINC-PLATED LOAD CHAIN

Zinc-plated Star Grade load chain protects against corrosion.

VARIABLE SPEED DRIVE (VFD) OR TRADITIONAL 2-SPEED UNITS AVAILABLE

PRIMARY & SECONDARY TRANSFORMER FUSING

LUG FOR MOUNTING TO PUSH, HAND-HEARED, AND MOTORIZED TROLLEY SUSPENSION

EXCEEDS H4 REQUIREMENTS

Lodestar NH exceeds H4 requirements. Engineered for high duty cycles and the toughest applications.

ECO-FRIENDLY

Lifetime grease-lubricated gearbox means no changing and disposing of hazardous oil. Documented RoHS compliance. Shipped in boxes made of recycled material.

METRIC RATED

CSA/US

National Recognized Testing Laboratory (NRTL)

LIFETIME WARRANTY

The industry's best warranty against manufacturing and material defects.

FABRIC CHAIN CONTAINER

Standard up to 20 ft. lift.

RIGID HOOK SUSPENSION

Rigid upper hook suspension is standard.

ROTATABLE LIMIT SWITCH

Designed for quick reset of limit position.

BLACK PHOSPHATE OR STAINLESS STEEL LOAD CHAIN

METAL & STAINLESS STEEL CHAIN CONTAINERS

KEY COMPONENTS

Working together, these key components provide best-in-class performance for any application in a wide variety of industries.

NOTE: Components shown do not represent 2-ton, single-reeved models.

LIFT WHEEL

The Lift Wheel's five pockets increase the engagement of the chain and lift wheel to provide smooth lifting with less vibration and reduced chain wear when properly maintained – ultimately extending the life of the chain.



MOTOR

Both heavy-duty and efficient, the motor is designed to operate on power supplies worldwide. Standard Class F insulation and thermal motor protection.

HOUSING

Cast aluminum, lightweight housing with acid-resistant, powder-coated finish for superior durability and protection against elements. Distinctive CM orange color allows for easy recognition after installation. The sealed drive shaft and standard weather-proofing gasket and seals provide the hoist with a NEMA 3R rating — suitable for outdoor use.

CONTROL PANEL

Easy access to plug & play connectors allow for quick voltage change for dual voltage motors. Effortless fuse installation when required.

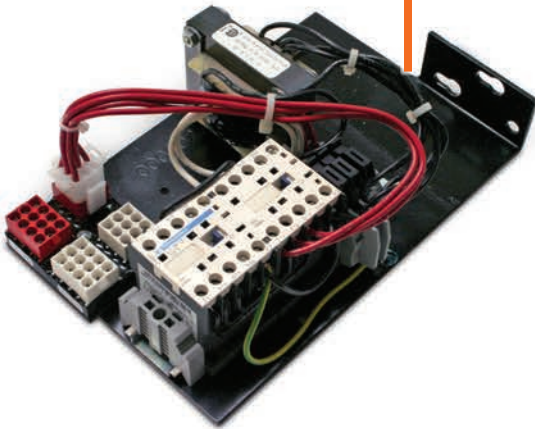

CLUTCH

Located outside the gear box for easy access, the clutch is designed to prevent lifting loads greater than rated capacity.

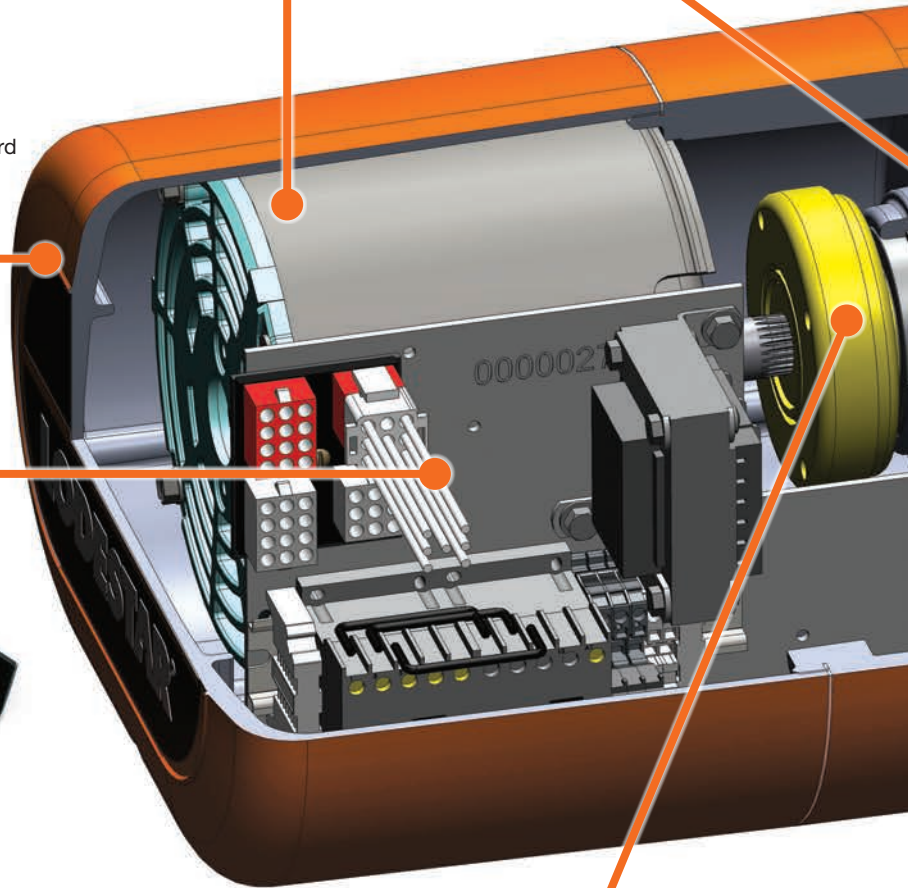

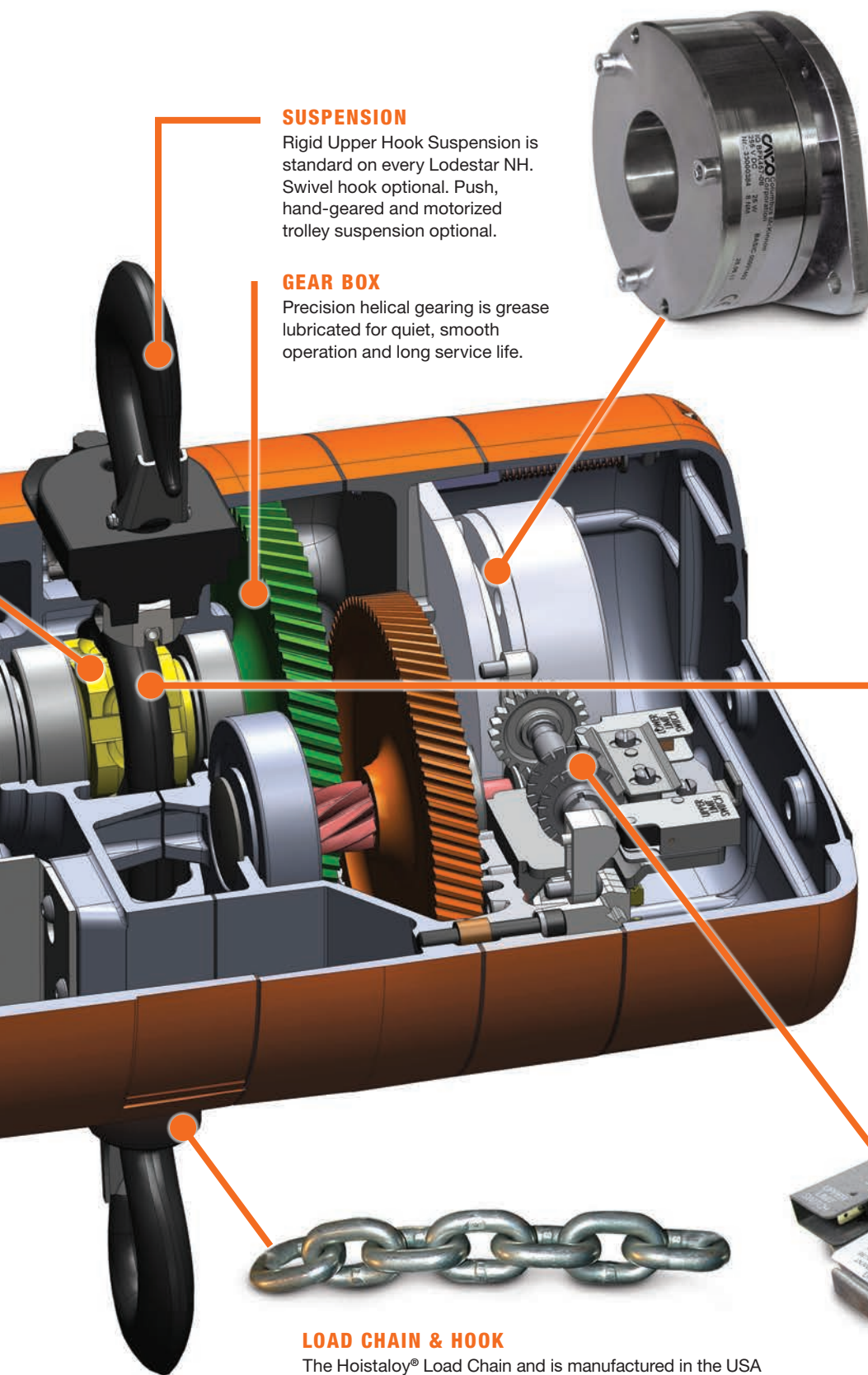

SUSPENSION

Rigid Upper Hook Suspension is standard on every Lodestar NH. Swivel hook optional. Push, hand-gear and motorized trolley suspension optional.

GEAR BOX

Precision helical gearing is grease lubricated for quiet, smooth operation and long service life.

BRAKE

Heavy-Duty DC Brake is standard. AC Brake and Double DC Brake are also available.



INTERNAL CHAIN GUIDE

The stamped steel chain guide, coated for corrosion resistance and quiet operation, keeps the load chain and liftwheel aligned during operation.



LOAD CHAIN & HOOK

The Hoistaloy® Load Chain and is manufactured in the USA by Stuart Rush. This ensures full compatibility and the highest quality control standards are met at all times. Load chain is zinc plated for protection against corrosion and is 100% proof tested.

FABRIC CHAIN CONTAINER

Standard on every Lodestar NH.

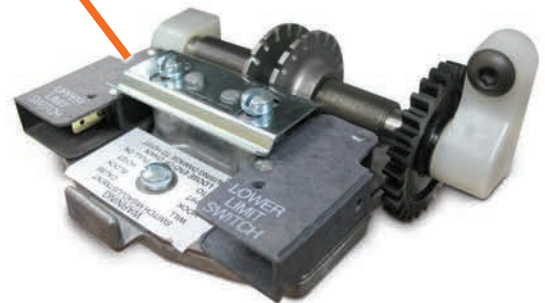

LIMIT SWITCH

Adjustable Screw Limit Switch that automatically stops the hook at any predetermined point when either lifting or lowering. Limits are field-configurable and can be adjusted to the specific application.

CM® LODESTAR NH

ELECTRIC CHAIN HOIST



2-TON, SINGLE-REEVED

The CM® Lodestar® NH is also available as an economical 2-ton, single-reeved unit that's ideal for a variety of industrial lifting applications. And, because it's a single-reeved unit, the design prevents the lower hook block from capsizing and damaging the hoist.

FEATURES AND BENEFITS

LESS MAINTENANCE & EASIER INSPECTION

- Brake location allows for quick access and easy inspection.
- Lifetime grease-lubricated gearbox means no oil change is required.
- Clutch located outside the gearbox allows for easy access which eliminates the need for complete disassembly and reduces downtime.

IMPROVED SERVICEABILITY

Easy access to the clutch, motor, electrical control panel and brake assembly.

LONGER SERVICE LIFE

- Heavy-duty DC brake is designed for a long service life.
- Lifetime grease-lubricated gearbox and helical gearing ensures better wear and smooth operation.
- Heavy-duty rated motors.

IMPROVED LOAD SAFETY

Clutch is located outside the load path, preventing slipping of the load in an overload condition when the brake is not powered.

OPTIONAL FEATURES

DOUBLE DC BRAKE

Two independent-acting DC Brakes for redundant braking. Field installation kit available.

IMPROVED CHAIN LIFE

5-Pocket Lift Wheel provides better chain and lift wheel engagement for smoother lifting and reduced vibration, equating to less wear and a longer chain life. Zinc plating protects chain from environmental conditions.

EASY ACCESS CONTROL PANEL

Finger-safe wiring and plug-and-play connectors on the control panel allow for quick voltage change, easy access to terminal strips and simple fuse installation.

ZINC-PLATED LOAD CHAIN

Designed and manufactured in the USA by Stuart Rush. 10-millimeter, zinc-plated Star Grade load chain protects against corrosion.

ADJUSTABLE LIMIT SWITCH

Easy-to-adjust screw limit switch automatically stops the hook at any predetermined point when either lifting or lowering, preventing overtravel.

OVERLOAD PROTECTOR

Helps prevent lifting of dangerous overloads.

METRIC RATED

LIFETIME WARRANTY

The industry's best warranty against manufacturing and material defects.

FABRIC CHAIN CONTAINER

Standard up to 20 ft lift.

RIGID HOOK SUSPENSION



VARIABLE SPEED DRIVE (VFD)

PRIMARY & SECONDARY TRANSFORMER FUSING

ROTATABLE LIMIT SWITCH

Designed for quick reset of limit position.

METAL CHAIN CONTAINERS



CM
LODESTAR

CM
LODESTAR
WARNING
DO NOT LET ANY PARTS OF
YOUR BODY OR ANY
PROPERTY COME IN CONTACT
WITH THE CABLE OR
CABLE ENDERS.
KEEP CLEAR OF THE
CABLE AND CABLE ENDS.
2014-01-01



2-TON, SINGLE-REEVED MODEL
SHOWN WITH A CM® UNIVERSAL
MOTORIZED TROLLEY

Every Stuart Rush product is engineered to help you work smarter, while improving the safety, uptime, and productivity of your operations.

STUART RUSH

LIFTING SOLUTIONS



USA & CA
p: 888.376.7510

WWW.STUART-RUSH.COM