

MODEL SLE**LOW-HEADROOM
ELECTRIC CHAIN HOISTS****CAPACITIES**

1 to 24 Tons

LIFT

10 Feet Standard

VOLTAGE230/460 Volt, 3-Phase,
60 Hz Standard

Chester SLE Electric Low Headroom Chain Hoists are designed for those applications where headroom is limited. Engineered around proven designs, these hoists provide smooth, quiet, trouble-free operation in a variety of H3 Duty applications. The units are equipped with worm drive gear reducers, case hardened load chain and are available in capacities from 1 through 24 tons. Choices of lug mounted push/pull, hand geared or motorized trolley drives are available to meet a variety of applications.

KEY FEATURES**5- OR 6-POCKET LOAD WHEELS**

Extends the life of the chain.

DURABLE SELF-LOCKING WORM DRIVE TRANSMISSIONS

Requires little maintenance.

STURDY STEEL CONSTRUCTION

For use in rugged applications.

DIRECT-ACTING MOTOR BRAKES

Sets automatically if power is interrupted.

TWO PRECISION BEARINGS PER TROLLEY WHEEL

Minimizes traversing effort.

REVERSING CONTACTORS

Allows for the motor to start in either direction, but contains an interlock to prevent the motor from being energized in both directions at the same time.

CASE-HARDENED LOAD CHAIN

For less wear and a longer chain life than through-hardened chain.

115V CONTROL TRANSFORMERS

24v or 48v controls available upon request.

TERMINAL BLOCKS IN A NEMA 12 ENCLOSURE

Provides protection to personnel against access to hazardous parts and protects against ingress of dirt and dust.

REDUNDANT PADDLE-TYPE AND GEARED LIMIT SWITCHES FOR BOTH UPPER AND LOWER HOOK TRAVEL

For added safety and control.

VARIOUS BEAM SIZES

Units can be supplied to fit a variety of beams including I-beams, wide flange beams and patented track.

**2-TON MODEL >****20-TON, EXPLOSION-PROOF/ >
SPARK-RESISTANT MODEL
WITH HAND GEARED TROLLEY**

OPTIONAL FEATURES

MAGNETIC MAINLINE CONTRACTOR

Includes buttons.

SPECIAL CONTROL ENCLOSURES

Special control enclosures and motors can be provided for hostile or hazardous environments including explosion proof applications. Units are available to meet customer specifications for equipment meeting Class I, Group D or Class II, Groups E, F or G criteria. Spark-resistant features are available when specified.

TROLLEY OPTIONS

Include plain, hand geared or a variety of motorized speeds. Motorized trolleys available as single or two speed, with additional options including VFD, trolley brake and soft starts.

PUSH BUTTON PENDANTS AND CONTROL CIRCUITS

Designed to meet the exact requirements of the customer. Control circuit options available include, nonstandard voltages, fuses, TOLs, current load limiters, trolley soft starts, two speed or variable speed operation, inching circuits, encoders, motor fuses, thermal overload relays and additional limit switches for hoist and trolley travel.

SPECIAL FINISHES AVAILABLE

Including plating and corrosion-resistant paints.

CHAIN CONTAINERS

Chain containers are designed to receive idle load chain as it reeves over the load sheave when lifting a load. This prevents the idle chain from interfering or marring and scratching the load or surrounding surfaces. Compact design helps maintain best possible headroom. Containers are available for most Chester hoist models.

OPTIONAL FEATURES

MAGNETIC MAINLINE CONTRACTOR

Includes buttons.

SPECIAL CONTROL ENCLOSURES

Units are available to meet customer specifications for equipment meeting Class I, Group D or Class II, Groups E, F or G criteria. Spark-resistant features are available when specified



**SPARK RESISTANT/EXPLOSION PROOF,
10-TON CHESTER LOW HEADROOM
ELECTRIC CHAIN HOIST IN USE
ON AN OFFSHORE OIL PLATFORM.**

SPECIFICATIONS

Capacity (tons)	Catalog Number			Standard Lift (ft.)	Minimum Headroom (in.)	Minimum Radius Curve **	Hoist Speed (FPM)	Motor HP & RPM	Motorized Trolley Speed (FPM)	Weight (lbs.)		
	Plain	Geared	Motorized							Plain	Geared	Motorized
1	ELP-1	ELG-1	ELM-1	10	7	6'6"	10	2@1,800	35	440	470	480
1-1/2	ELP-11/2	ELG-11/2	ELM-11/2	10	7	6'6"	10	2@1,800	35	440	470	480
2	ELP-2	ELG-2	ELM-2	10	7	6'6"	10	2@1,800	35	440	470	480
3	ELP-3	ELG-3	ELM-3	10	8	6'6"	5	2@1,800	35	540	570	580
4	ELP-4	ELG-4	ELM-4	10	8-1/2	7'6"	5	2@1,800	35	540	570	580
5	ELP-5	ELG-5	ELM-5	10	9-1/2	8'6"	7	4@1,200	35	1,280	1,340	1,310
6	ELP-6	ELG-6	ELM-6	10	9-1/2	8'6"	7	4@1,200	35	1,280	1,340	1,310
8	ELP-8	ELG-8	ELM-8	10	12	9'6"	4	4@1,200	20	1,350	1,480	1,400
10	ELP-10	ELG-10	ELM-10	10	12-1/2	10'	3.5	4@1,200	20	1,730	1,810	1,780
12	ELP-12	ELG-12	ELM-12	10	12-1/2	*	3.5	4@1,200	20	1,730	1,810	1,780
16	ELP-16	ELG-16	ELM-16	10	14-1/2	*	2	4@1,200	20	2,300	2,380	2,350
20	ELP-20	ELG-20	ELM-20	10	18	*	1.7	4@1,200	20	2,650	2,810	2,750
24	ELP-24	ELG-24	ELM-24	10	18	*	1.7	4@1,200	20	2,650	2,810	2,750

* Straight track operation only recommended for these units. However curve radius must be specified on orders.

** Curves less than minimum may be fitted by special construction. Please consult factory.

NOTE: All headroom dimensions determined while hoist under load.

MODEL SLE LOW-HEADROOM ELECTRIC CHAIN HOISTS

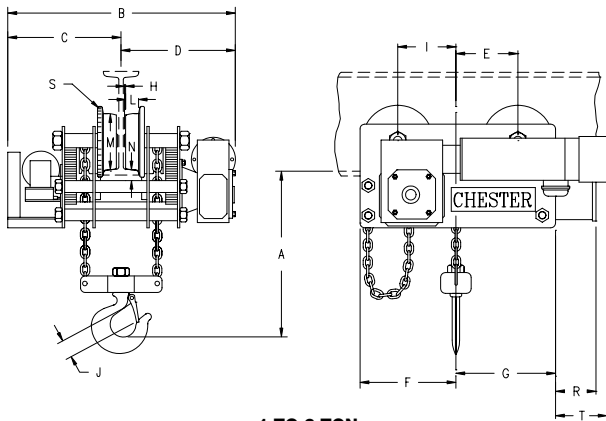

1 TO 2 TON
PLAIN, GEARED & MOTORIZED

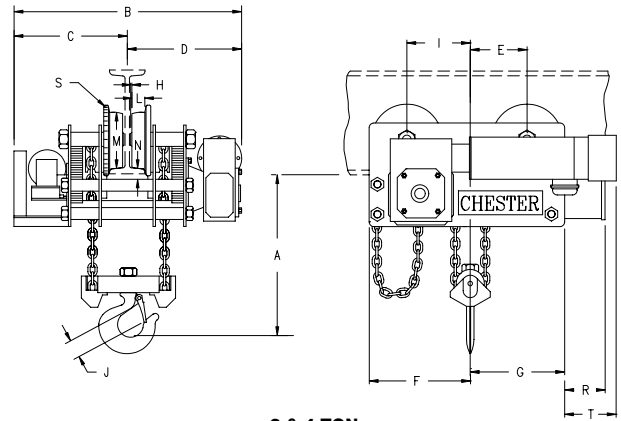

3 & 4 TON
PLAIN, GEARED & MOTORIZED

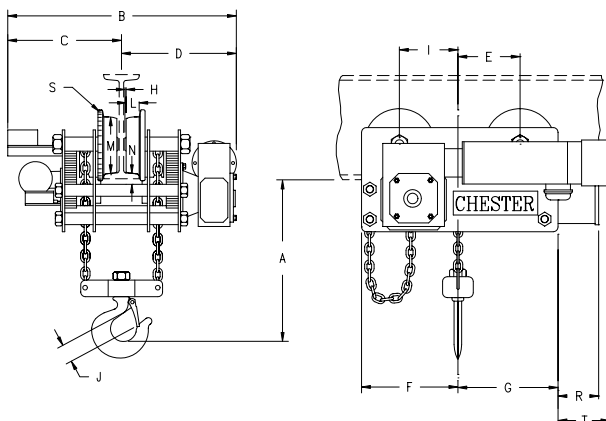

5 & 6 TON
PLAIN, GEARED & MOTORIZED

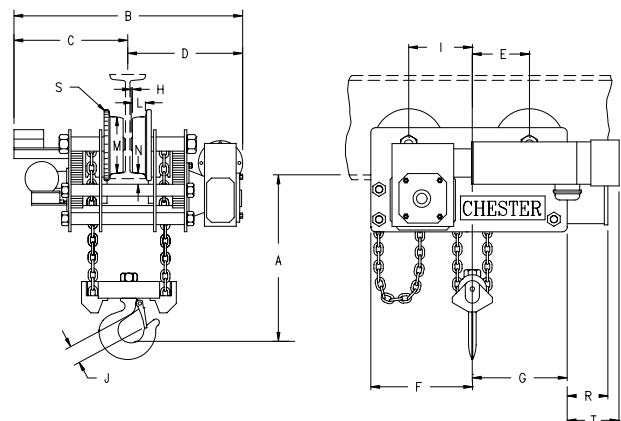

8 TON
PLAIN, GEARED & MOTORIZED

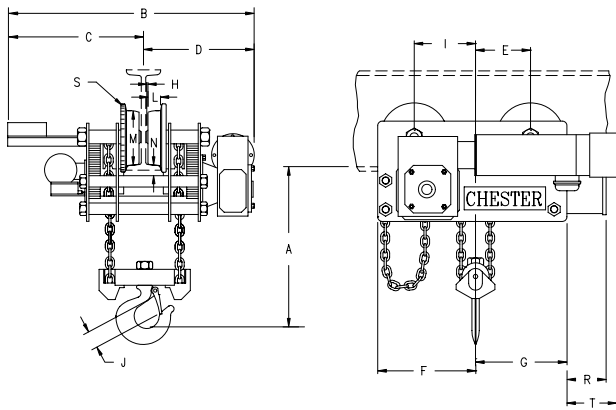

10 & 12 TON
PLAIN, GEARED & MOTORIZED

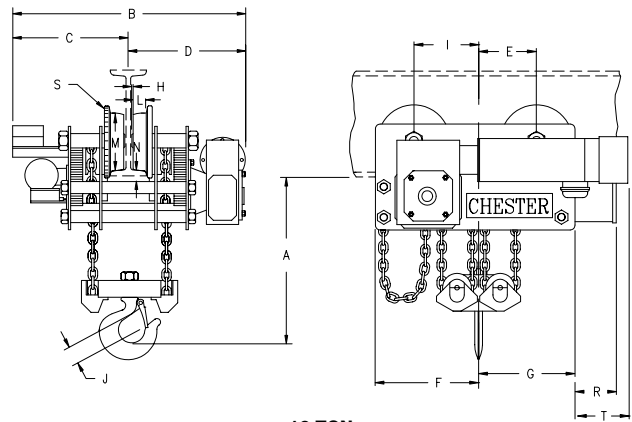

16 TON
PLAIN, GEARED & MOTORIZED

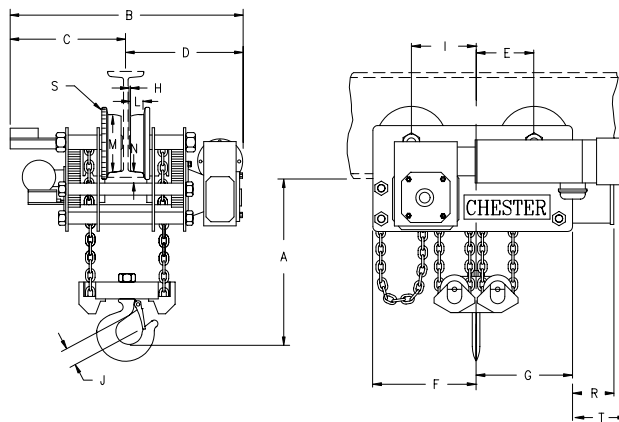

20 & 24 TON
PLAIN, GEARED & MOTORIZED

DIMENSIONS

Capacity (tons)	Dimensions (In.)																	
	A*	B	C	D	E	F	G	H**	I	J	L	M	N***	R	S	T	Min Beam	Beam Width
1	7	33-13-16	16-1/2	17-5/16	7-3/4	10	10	1/16	7-3/4	1-1/8	1-1/8	4-1/2	7/8	6-1/2	6	9-1/4	S6x12.5#	3.332"
1-1/2	7	33-13-16	16-1/2	17-5/16	7-3/4	10	10	1/16	7-3/4	1-1/8	1-1/8	4-1/2	7/8	6-1/2	6	9-1/4	S6x12.5#	3.332"
2	7	33-13-16	16-1/2	17-5/16	7-3/4	10	10	1/16	7-3/4	1-1/8	1-1/8	4-1/2	7/8	6-1/2	6	9-1/4	S6x12.5#	3.332"
3	8	33-13/16	16-1/2	17-5/16	9	13	13	1/4	9	1-11/32	1-11/32	6-3/8	15/16	6-1/2	8	8	S8x18.4#	4.001"
4	8	33-13/16	16-1/2	17-5/16	9	13	13	1/4	9	1-11/32	1-11/32	6-3/8	15/16	6-1/2	8	8	S8x18.4#	4.001"
5	9-1/2	50-1/2	23-1/2	27	7-3/8	12	15	0	7-3/8	1-11/16	1-13/32	7-3/16	1-1/8	6-1/2	9	12	S10x25.4#	4.661"
6	9-1/2	50-1/2	23-1/2	27	7-3/8	12	15	0	7-3/8	1-11/16	1-13/32	7-3/16	1-1/8	6-1/2	9	12	S10x25.4#	4.661"
8	12	50-1/2	23-1/2	27	8-3/8	14	13-1/2	3/16	8-7/8	2-1/16	1-11/16	8-1/4	1	6-1/2	10	12	S10x25.4#	4.661"
10	12-1/2	50-1/2	23-1/2	27	8-1/2	15-5/8	14-3/8	3/8	9-3/4	2-1/4	1-3/4	9-3/4	1-1/8	6-1/2	11-11/16	9	S12x31.8#	5"
12	12-1/2	50-1/2	23-1/2	27	8-1/2	15-5/8	14-3/8	3/8	9-3/4	2-1/4	1-3/4	9-3/4	1-1/8	6-1/2	11-11/16	9	S12x31.8#	5"
16	14-1/2	54-1/2	25-1/2	29	11-7/8	18-5/8	18-5/8	3/8	11-7/8	3	2	11-3/4	1-1/8	6-1/2	14-13/32	3-1/2	S15x42.9#	5.501"
20	18	54-1/2	25-1/2	29	12-1/8	19-1/4	19	3/8	12-3/8	3-5/8	2	11-3/4	1-3/16	6-1/2	14-13/32	2-1/2	S18x54.7#	6.001"
24	18	54-1/2	25-1/2	29	12-1/8	19-1/4	19	3/8	12-3/8	3-5/8	2	11-3/4	1-3/16	6-1/2	14-13/32	2-1/2	S18x54.7#	6.001"

* To wheel-running surface of beam
 ** To under beam roller - closest point of contact
 *** From face of the wheel to the end of the axlet
 NOTE: must take flange width and thickness of beam into consideration.
 Flat tread wheels (supplied for "W" beams) not shown.