

LODESTAR®

ELECTRIC CHAIN MOTOR

CAPACITIES

250 kg to 2000 kg

LIFT

18 metre standard***

SPEEDS

4 to 16 metre/minute

VOLTAGES

1-phase & 3-phase available

From World touring rock concerts and Broadway musicals to Las Vegas shows and sporting events, the CM Lodestar is the trusted industry workhorse.

The New Generation Lodestar complies with BGV-D8.

STANDARD FEATURES

IP 65 RATING

An Ingress Protection (IP) Rating of 65 indicates that the Lodestar offers protection from dust and high-pressure water – making this unit ideal for use in outdoor environments.

ADJUSTABLE CLUTCH

Clutch outside of gear train meets International standards and is fully adjustable. Designed to prevent damage to the hoist by preventing excessive overloads.

5 POCKET LIFTWHEEL

Improved chain life & smooth lifting.

PRECISION HELICAL GEARING

Designed for long life, and smoother operation.

REDESIGNED CONTROL PANEL

For easier access.

HEAVY DUTY DC BRAKE

Designed for a long service life, the brake location allows for quick access & easy inspection.

LOW VOLTAGE CONTROL

110 Volt for long cable runs without voltage drop. 24 & 48 Volt optional. (Low Voltage Unit Only)

DURABLE & LIGHTWEIGHT HOUSING

Cast aluminum. Black powder coated finish for low visibility.

LOAD CHAIN

Designed and manufactured by Columbus McKinnon to provide a factor of safety of 8:1. Zinc plated to protect against corrosion. Optional black finish available.

DUTY CYCLE

H4, FEM 2M rated for heavy duty applications.

ELECTRICAL

Finger safe wiring meets all electrical codes. Quick change plugs allow for voltages 230 through 460. Prevents improper voltage connections which can cause hoist damage. (Low Voltage Unit Only).

ADJUSTABLE LIMIT SWITCH

Adjustable limit switch that will automatically stop the hook at any predetermined point when either lifting or lowering, preventing overtravel. (Low Voltage Unit Only).

METRIC RATED MEETS REQUIREMENTS

Meets or exceeds world standards.

ROAD READY

Easy to stow and travel.



LIFT WHEEL
5 Pocket liftwheel increases chain and liftwheel engagement while providing smoother lifting, less vibration and reduced chain wear when properly maintained.



ADJUSTABLE CLUTCH
Designed to prevent lifting of excessive overloads. Located outside the gear box and easy to access.

CONTROL PANEL
Provides easy access to controls, plug and play connectors allow for quick voltage change for dual voltage motors. Fuses located on terminal strip (optional).

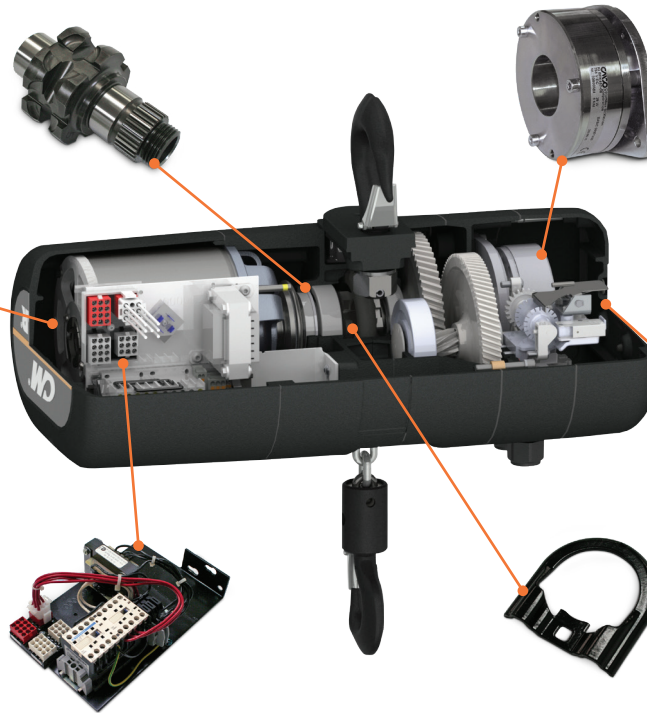

BRAKE
Heavy duty DC brake is standard. AC brake and double DC brake are also available.

LIMIT SWITCH (Low Voltage unit only)
Adjustable limit switch that will automatically stop the hook at any predetermined point when either lifting or lowering.

INTERNAL CHAIN GUIDE
Stamped steel guide coated for corrosion resistance and quiet operation, while keeping the load chain and liftwheel aligned.

DIMENSIONS

Drawing Legend	Dimensions (mm)		
	D8 Series B, C, F	D8 Series J, L, LL	D8 Series R, RR
A	413mm	472mm	613mm
B	1154mm	194mm	194mm
C	17mm	22mm	29mm
D	297mm	253mm	253mm
F	225mm	329mm	329mm
H	25mm	30mm	38mm
I	107mm	145mm	179mm
J	113mm	176mm	142mm
M	25mm	28mm	33mm
P	168mm	208mm	208mm

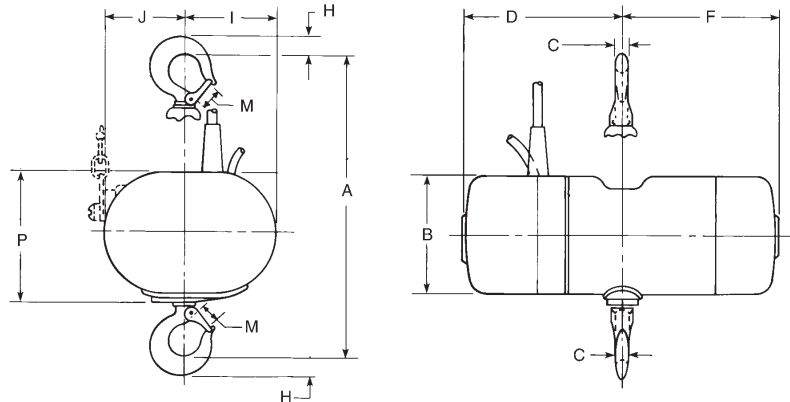

SPECIFICATIONS

Type	Rate Capacity	Standard Lifting Speed at 50Hz	Operating Voltage	Single Phase Voltage	FEM Class	Chain Weight Per Metre Lift-EWL	Load Chain EN 818-7 (mm)	Power Consumption - Full Load	Reeves Fall of Chain	Motor HP	Protection Class	Noise Level
Model B	250kg	4m/min	400-3-50	optional	2M	1.2kg	6.3 x 18.9	1.1A	1	1/4 HP	IP 65	68 db (A)
Model C	250kg	8m/min	400-3-50	optional	2M	1.2kg	6.3 x 18.9	1.2A	1	1/2 HP	IP 65	68 db (A)
Model F	500kg	4m/min	400-3-50	optional	2M	1.2kg	6.3 x 18.9	1.2A	1	1/2 HP	IP 65	68 db (A)
Model J	500kg	8m/min	400-3-50	-	2M	1.65kg	7.9 x 21.7	2.3A	1	1 HP	IP 65	68 db (A)
Model JJ	500kg	16m/min	400-3-50	-	2M	1.65kg	7.9 x 21.7	3.6A	1	2 HP	IP 65	68 db (A)
Model L	1000kg	4m/min	400-3-50	optional	2M	1.65kg	7.9 x 21.7	2.3A	1	1 HP	IP 65	68 db (A)
Model LL	1000kg	8m/min	400-3-50	-	2M	1.65kg	7.9 x 21.7	3.6A	1	2 HP	IP 65	68 db (A)
Model R	2000kg	2m/min	400-3-50	optional	2M	3.3kg	7.9 x 21.7	2.3A	2	1 HP	IP 65	68 db (A)
Model RR	2000kg	4m/min	400-3-50	-	2M	3.3kg	7.9 x 21.7	3.6A	2	2 HP	IP 65	68 db (A)

*** Lifts other than 18 metres available (Standard Units shipped less chain unless specified). Consult factory for additional speeds and capacities

OPTIONAL FEATURES

DOUBLE DC BRAKE
Two independent acting DC brakes for redundant braking. Field installation kit available.

DOUBLE LIMIT SWITCH
Adjustable screw limit switch that will automatically stop the hook at any predetermined point when either lifting or lowering.

VARIABLE SPEED UNITS AVAILABLE (VFD)
Varistar or variable speed versions available, please contact your CM-ET sales representative for details.

CHAIN BAGS
Cloth type bags are durable and easy to mount.

DIRECT CONTROL UNITS
The CM Lodestar is available as a Direct Control Unit featuring a single cable. Direct Control Units can be used as part of a system with multiple units with a single control. The Lodestar is compatible with most Direct Control Motor Controllers.

2-TONNE, SINGLE REEVED MODELS (see page 8)